

Mechanical Power Take-Off

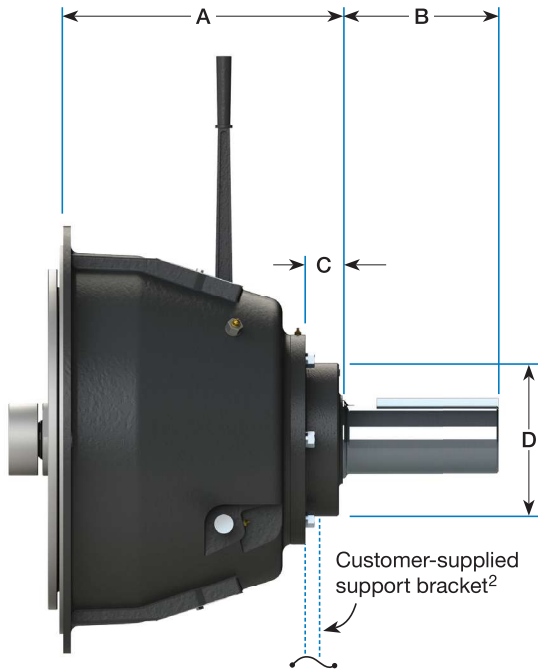

The WPT® Mechanical Power Take-Off consists of a lever-actuated clutch with a shaft and bearings mounted in a rigid cast housing. The Mechanical PTO is designed for inline and sload applications on all internal combustion engines with standard SAE industrial flywheel/flywheel housing dimensions.

- Sealed-for-life pilot bearings eliminate lubrication problems.
- Ball bearing throwout collars are optional on 10", 11 1/2", 14" and 18". Standard on the 311 PTO.
- All drive rings are ductile (nodular) iron or steel.

Model	SAE Housings	A	Output Shaft			C	D	Weight lb (kg)	# of Teeth
			B	Dia	Keyway				
C106 ¹ C107 ¹	5, 4	7 1/8 (181.0)	3 1/2 (88.9)	1.438 (36.53)	3/8 x 3/16	2 1/8 (54.0)	4 5/8 (117.5)	65 (30)	42
C108	5, 4, 3	7 1/8 (181.0)	6 (152.4)	1.750 (44.45)	1/2 x 1/4	2 1/4 (57.2)	5 (127.0)	82 (37)	51
C110	4, 3	8 5/8 (219.1)	5 1/2 (139.7)	2.250 (57.15)	5/8 x 5/16	3 3/4 (95.3)	5 5/8 (142.9)	117 (53)	63
SP111	3, 2, 1	9 1/4 (235.0)	6 1/2 (165.1)	2.250 (57.15)	5/8 x 5/16	3 3/4 (95.3)	5 3/4 (146.1)	143 (65)	72
SP211	3, 2, 1	9 5/8 (244.5)	6 1/2 (165.1)	2.500 (63.50)	5/8 x 5/16	3 (76.2)	6 1/4 (158.8)	157 (71)	72
SP311 ²	3, 2	13 7/8 (352.4)	10 (254.0)	3.500 (88.90)	7/8 x 7/16	3 3/8 (85.7)	7 1/2 (190.5)	233 (106)	72
SP114	1	12 1/8 (308.0)	8 1/2 (215.9)	3.000 (76.20)	3/4 x 3/8	3 3/4 (95.3)	6 5/8 (168.3)	263 (119)	59
SP214 ²	1, 0	13 3/4 (349.3)	10 (254.0)	3.500 (88.90)	7/8 x 7/16	3 3/8 (85.7)	7 1/2 (190.5)	332 (151)	59
SP314 ²	1, 0	14 1/2 (368.3)	10 (254.0)	3.938 (100.01)	1 x 1/2	3 3/8 (85.7)	7 1/2 (190.5)	413 (187)	59
IBF314 ²	1, 0	16 3/4 (425.5)	10 (254.0)	3.938 (100.01)	1 x 1/2	3 5/8 (92.1)	12 1/2 (317.5)	595 (270)	59
SP318 ²	0	18 1/4 (463.6)	10 (254.0)	4.500 (114.30)	1 x 1/2	2 5/8 (66.7)	10 (254.0)	897 (407)	75

¹ Double main bearings

² Support plate for 311, 214, 314 is required for sload applications and recommended for inline applications. Support plate for 318 is required for both sload and inline applications.