

# Type 1 Power Take-Off

The Type 1 PTO is one of the most rugged, highest capacity products available on the market today. With the sheave mounted between the bearings, these power take-offs are designed to attain the maximum potential of their massive spherical roller bearings.

Some benefits of the WPT® Type 1 include: Potential for remote engagement, self-adjusting clutch, air or hydraulic actuation, heavy-duty gear tooth friction discs and easy drive belt removal.

Gen II Type 1 PTO's make it possible to house mechanical, hydraulic or pneumatic clutch pack. In addition, the sheave housing is designed with internal and external pilots, vastly improving the quality and ease of field repairs while increasing uptime.

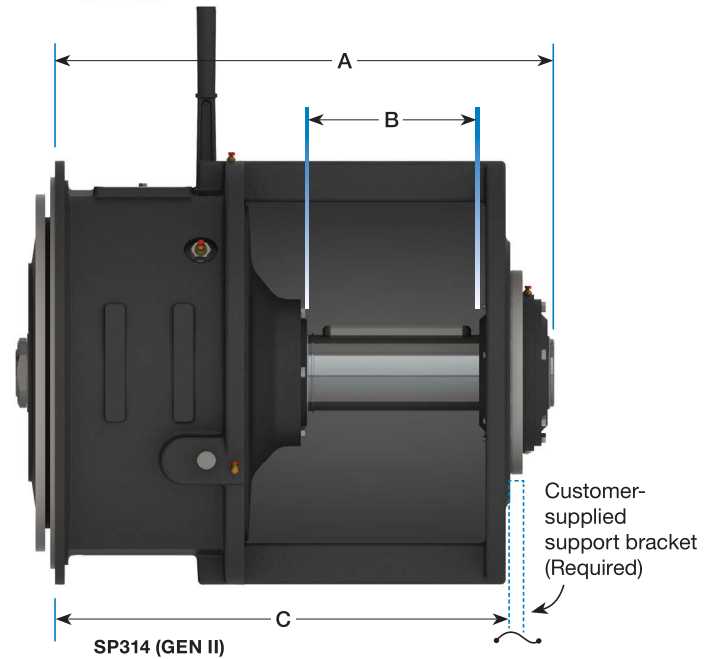
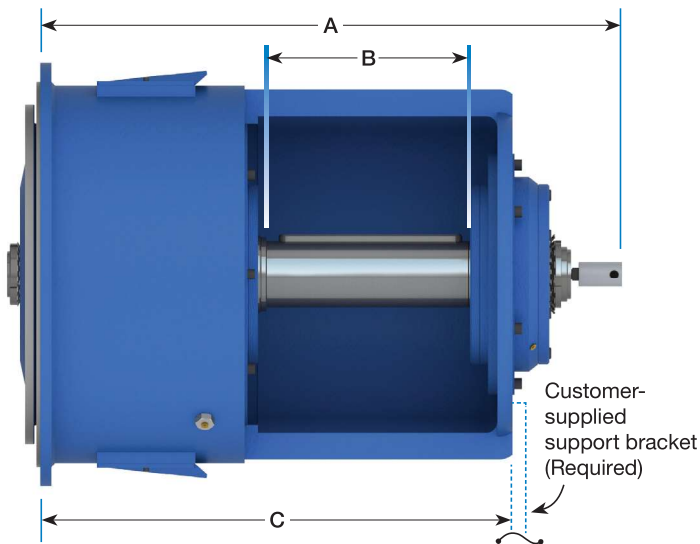

Model	SAE Housings	A	Output Shaft			C	Sheave (Customer Supplied)	
			B	Dia	Keyway		Max Dia	Max Width <sup>1</sup>
314H (GEN II)	1, 0	29 1/2 (749.3)	9 1/2 (241.3)	3.938 (100.00)	1 x 1/2	23 7/8 (606.4)	17 (431.8)	12 7/8 (327.0)
SP314 (GEN II)	1, 0	28 5/16 (718.6)	9 1/2 (241.3)	3.938 (100.00)	1 x 1/2	23 7/8 (606.4)	17 (431.8)	12 7/8 (327.0)
318	0	38 3/4 (984.3)	13 5/16 (338.1)	4.500 (114.30)	1 x 1/2	31 1/2 (800.1)	18 (457.2)	15 5/16 (388.9)
318/Ext Version	0	44 3/4 (1136.7)	19 5/16 (490.5)	4.500 (114.30)	1 x 1/2	37 1/2 (952.5)	18 (457.2)	21 3/8 (542.9)
321	00	44 5/8 (1133.5)	19 15/16 (506.4)	4.750 (120.65)	1 1/4 x 5/8	39 3/4 (1009.7)	23 (584.2)	22 (558.8)
321/Short Version	00	35 5/8 (904.9)	11 (279.4)	4.750 (120.65)	1 1/4 x 5/8	30 3/4 (781.1)	23 (584.2)	13 (330.2)
321/Ext Version	00	47 5/8 (1209.7)	23 (584.2)	4.750 (120.65)	1 1/4 x 5/8	42 3/4 (1085.9)	23 (584.2)	25 (635.0)

<sup>1</sup> Maximum sheave width varies with sheave diameter. Tabulated value is at the maximum sheave diameter.